

For technical support, contact: 011 202 5884 or 083 235 4916.

SMS ALERT GATE OPENER Programming Guide



Quick startup guide

Hardware connection:

- 1.1 Open the bottom cover by removing the 4 screws.
- 1.2 Insert SIM-card into the SIM slot.
- 1.3 Connect GSM antenna to ANTENNA connector.
- 1.4 Connect Control pins to RELAY cable
- 1.5 Connect Power supply to POWER SUPPLY cable.
- 1.6 **Power up for at least 5 minutes before sending any SMS's.**
- 1.7 When power supply is ON:
The red LED will start blinking 1 second on, 1 second off – searching for cellular network.
After 30 seconds, the red Led will go on and then off.
When the green LED is on, the unit is ready to use.

Add new phone number to the unit:

To add a phone number to the unit send the following SMS to the unit:
Example: add new phone number 0541122333 with unit password 1234:

P.1234A.0541122333

The SMS Alert Gate Opener will send back an SMS to notify the new phone number was added.
The unit is now ready to use. You can call the unit and check if the relay is working,
The Green Led will blink one time when you call.

Connection diagram:

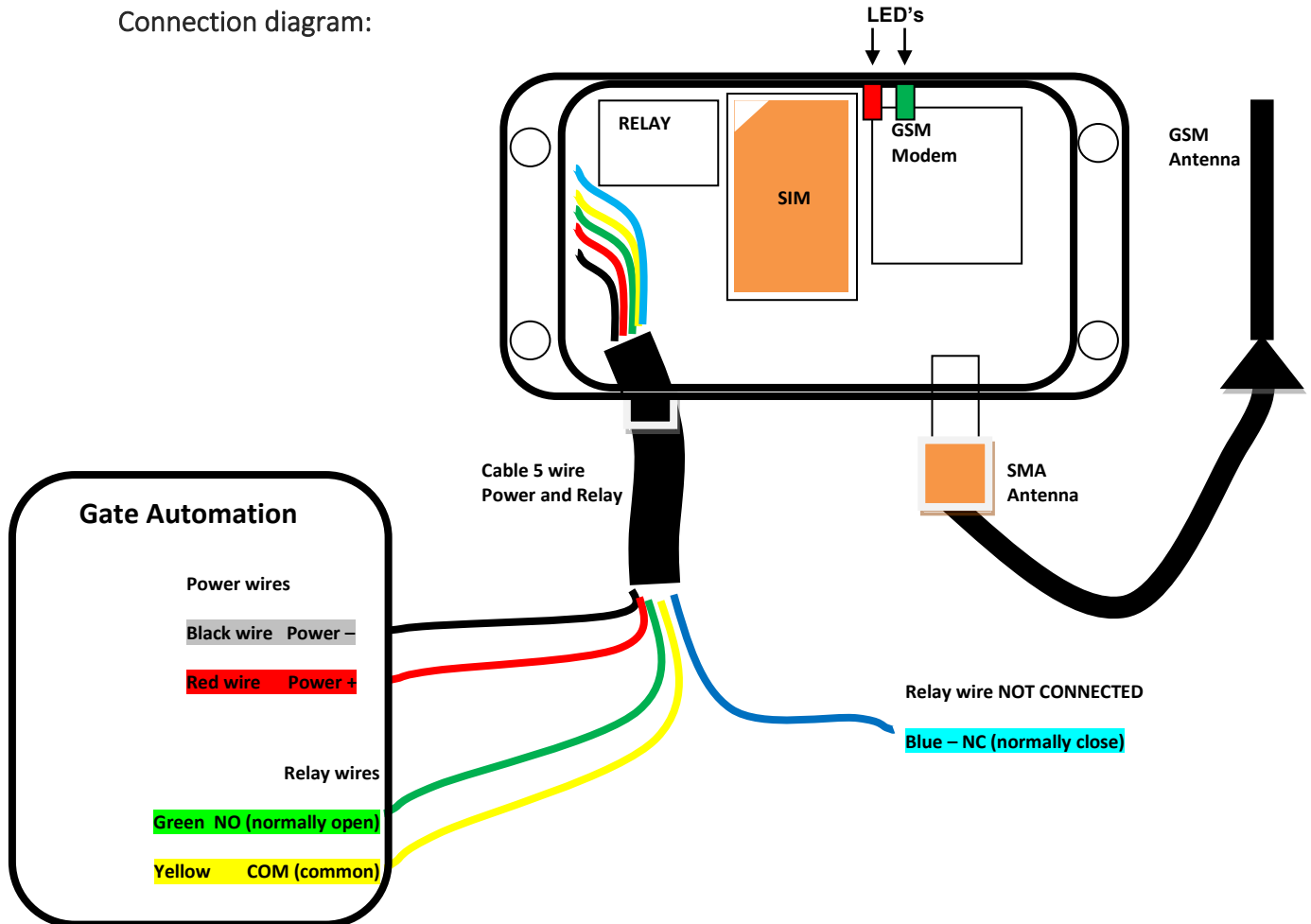

SMS programming guide

Every SMS command sent to the unit, must start with P.<password>
 Example: add new phone number 0541122333 with unit password 1234:
P.1234A.0541122333

The SMS unit password is the same as the GTO unit password.
 The password used in all the examples in this section is 1234.
 The unit ignores messages that do not start with p.<password> or if the password is incorrect.

After analysing the SMS commands, the unit respond to the sender confirmation or error message (in order to get return message, the unit SIM card must have SMS send option).

The SMS command must not exceed 160 characters.
 All the characters in the SMS must be in the same letter case (all uppercase or lowercase).
 In the examples below uppercase characters have been used.



1. Add new phone numbers

Add new phone numbers to the regular phone list.

Syntax: A.<phone number>.<phone number>....

Use a dot to separate the phone numbers from each other.

Example: **P.1234A.0547512152.0525874525**

Add 0547512152 and 0525874525 to the phone list

2. Add new restricted phone number

From time to time in specific week days user.

Add new restricted user in From time To time in specific week days mode.

Syntax: AS.<phone number>.1.<HHMM>.<HHMM>.<week days>

Weekdays: 1-Sunday, 2-Monday...

Example 1: **P.1234AS.058126248.1.1130.1540.135**

Phone number 058126248 will be allowed to enter from 11:30 to 15:40 on Sunday, Tuesday and Thursday.

Example 2: **P.1234AS.058126248.1.2300.0200.24**

Phone number 058126248 will be allowed to enter from 23:30 to 02:00 on Monday and Wednesday.

From date To date

Not supported in SMS commands

Number of entries

Add new restricted user in number of entries mode.

Syntax: AS.<phone number>.3.<amount of entries>

Example 1: **P.1234AS.058126248.3.6**

Phone number 058126248 will be allowed to enter 6 times.

3. Delete phone number

Delete phone numbers from the regular phone list.

Syntax: D.<phone number>.<phone number>....

Use a dot to separate the phone numbers from each other.

Example: **P.1234D.0547512152.0525874525**

Delete 0547512152 and 0525874525 from the regular phone list.

4. Delete restricted phone number

Delete phone numbers from the restricted phone list.

Syntax: DS.<phone number>.<phone number>....

Use a dot to separate the phone numbers from each other.



Example: **P.1234DS.0547512152.0525874525**

Delete 0547512152 and 0525874525 from the restricted phone list

5. Format/Erase the entire users list

Erase the entire phone list, regular and restricted.

Syntax: **FORMAT**

Example: **P.1234FORMAT**

6. Define the gate delay

Write the gate delay in seconds.

Gate delay defines the time that the outputs will be activated.

Syntax: **GOD.<gate delay>**

Example: **P.1234GOD.7**

Set the gate open to 7 seconds delay.

7. Update the unit clock

Update the unit clock from the SMS time stamp.

Syntax: **CU**, Example: **P.1234CU**

8. New unit password

Change the current password.

Syntax: **NP.<new password>**

Example: **P.1234NP.4321**

Change the unit password to 4321.

9. Enable\disable the unit

Disable or enable the entire unit.

While the unit is disabled, all the incoming calls will be rejected.

Syntax: **EN.{0,1}**

Example: **P.1234EN.1**

Enable the unit

Example: **P.1234EN.0**

Disable the unit

10. Allow access to everyone (open everyone)

Ignore the phone list (regular and restricted) and allow everyone to activate the relay output (output 2 and output 3 are not accessible in this mode).

Syntax: OPEN.{0,1}

Example: **P.1234OPEN.1**

Allow access to everyone.

Example: **P.1234OPEN.0**

Normal operation.

11. Retrieve the unit information

Retrieve information about the unit:

- Amount of numbers in the phone list
- Amount of numbers in the restricted phone list
- Reception level
- Unit Enable\Disable
- Open everyone Enabled\Disabled

Syntax: INFO, Example: **P.1234INFO**

12. Retrieve the unit firmware version

Syntax: VER, Example: **P.1234VER**

13. Overview

The SMS Alert Gate Opener is a complete system solution for cellular gate\door access control.

The unit stores a list of authorized users; when someone calls the unit, the unit hangs-up the call and check if the caller ID exists in the list. If it does, a pulse generated by internal relay command the gate\door to open.

The is no call cost for the user.

The unit holds up to 1600 authorized users and up to 400 restricted (limited) users (total: 2000 users).

14. General Product Description

14.1 Dimensions

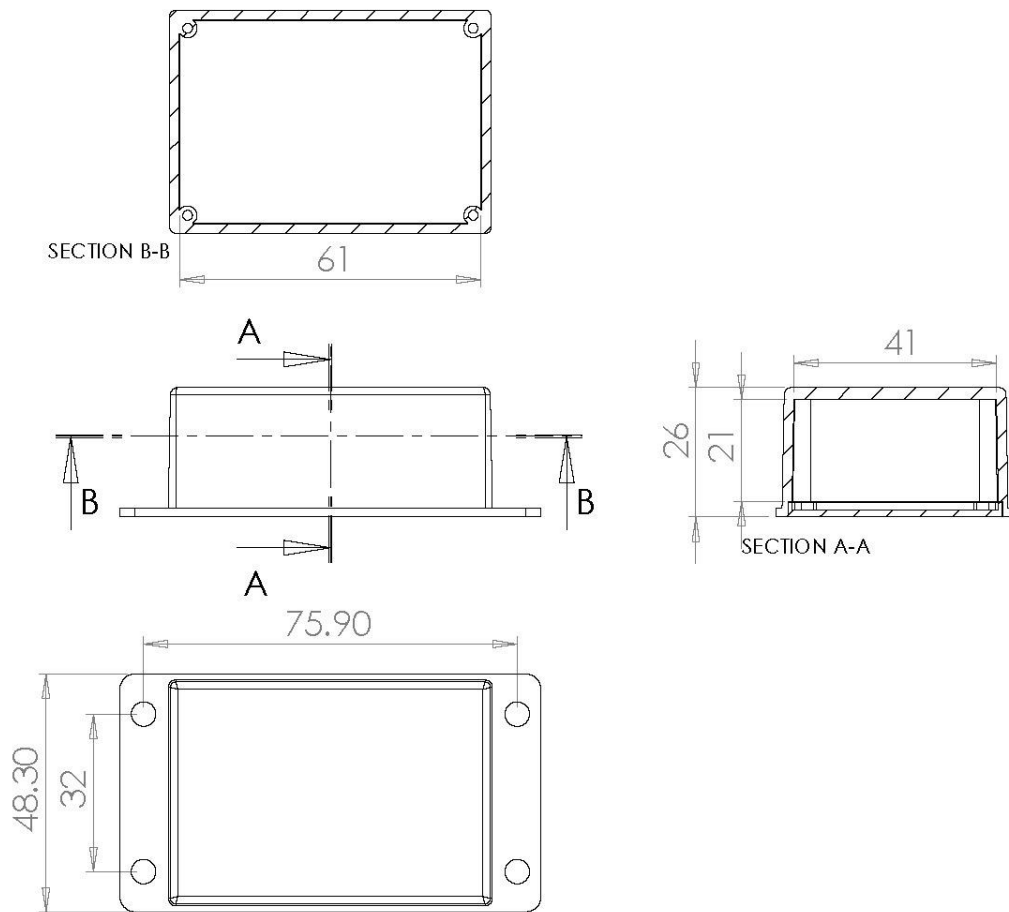

14.2 Weight

120 grams.

14.3 Input voltage

5V-30V DC 1A

14.4 Casing material

The case made from plastic PC

Avoid exposing the unit to liquid or moisture

14.5 Temperature range

	Ambient temperature in plastic enclosure	Note
--	--	------

Operating Temperature Range	-20°C to +55°C	The unit is fully functional in all the temperature range, and it fully meets the ETSI specification
	-40°C to +85°C	The module is fully functional in all the temperature range. Temperatures outside the range -20°C to +55°C, might slightly deviate from ETSI specifications
Storage and Non Operating Temperature Range	-40°C to +85°C	

14.6 Air humidity range

5% - 85%

14.7 RoHS compliance

All hardware components are fully compliant with the EU RoHS and WEEE Directives.

15. GSM frequencies

The unit supports quad band GSM frequencies:

- GSM-850
- E-GSM-900
- DCS-1800
- PCS-1900
- Currently 2G only (LTE final release end of 2021)

- 16. Installation

Connection diagram

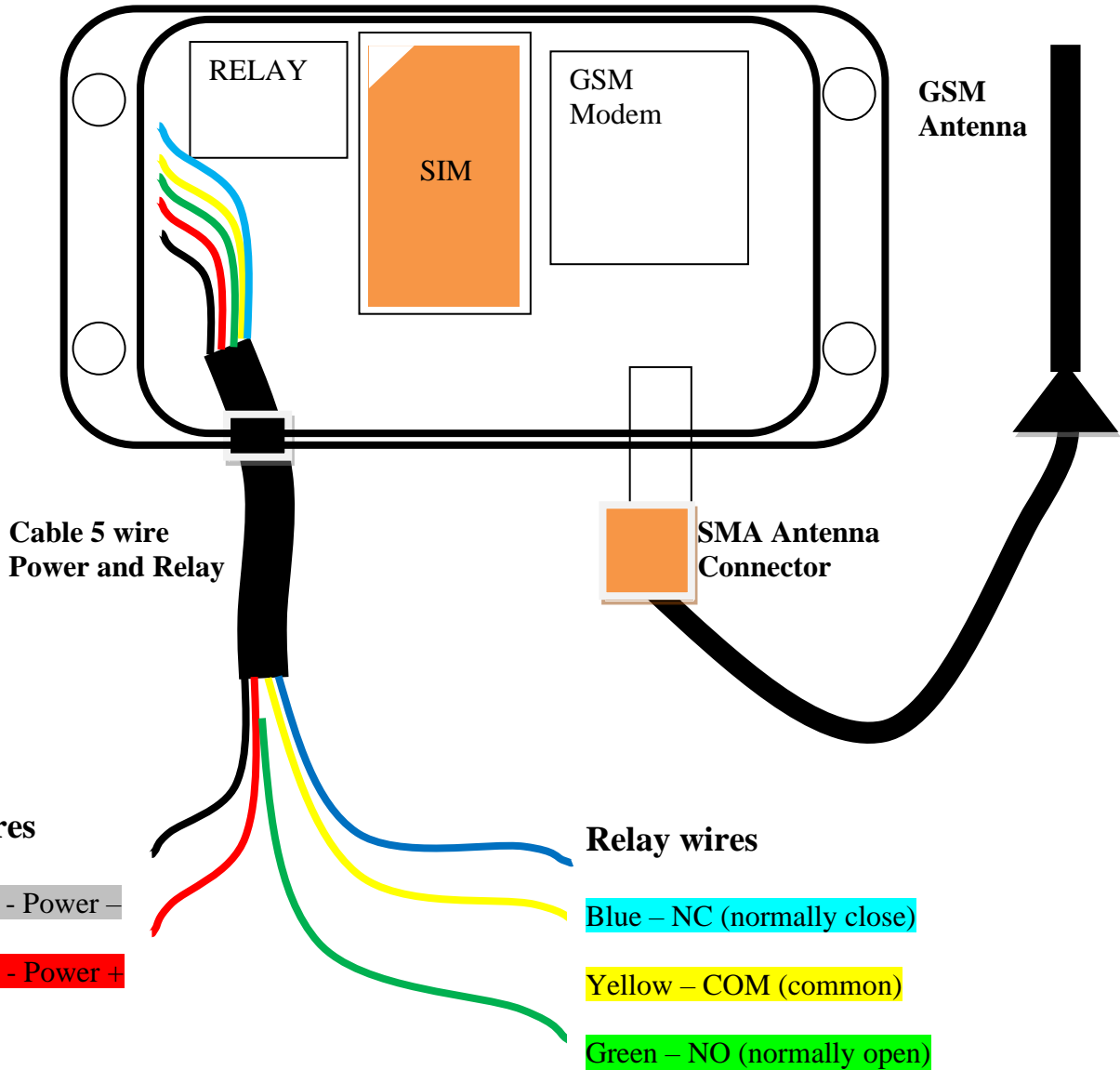

17. SIM card insertion

Open the SIM-card holder with a screw driver and insert the SIM card.

Make sure the SIM-card is capable of receiving incoming SMS messages and to identify a caller ID. If the SIM needs a PIN code please use 1111.

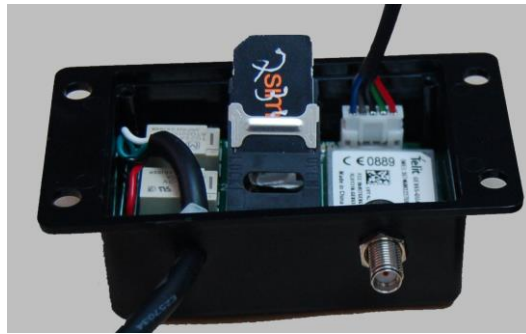

18. Status Led's

Red LED displays the network status of the SMS Alert Gate Opener.

Red LED status	Device Status
permanently on	a call is active
fast interrupt sequence (period 0,5s, Ton 1s)	Net search / Not registered / turning off
slow interrupt sequence (period 0,3s, Ton 3s)	Registered full service
permanently off	device off

Green LED displays the operating status of the SMS Alert Gate Opener

Green LED status	Device Status
permanently ON	Unit active
fast interrupt sequence (period 1s, Ton 1s)	Error: Net search / Not registered
OFF for 1s and then ON	Unit get phone call
permanently OFF	device off

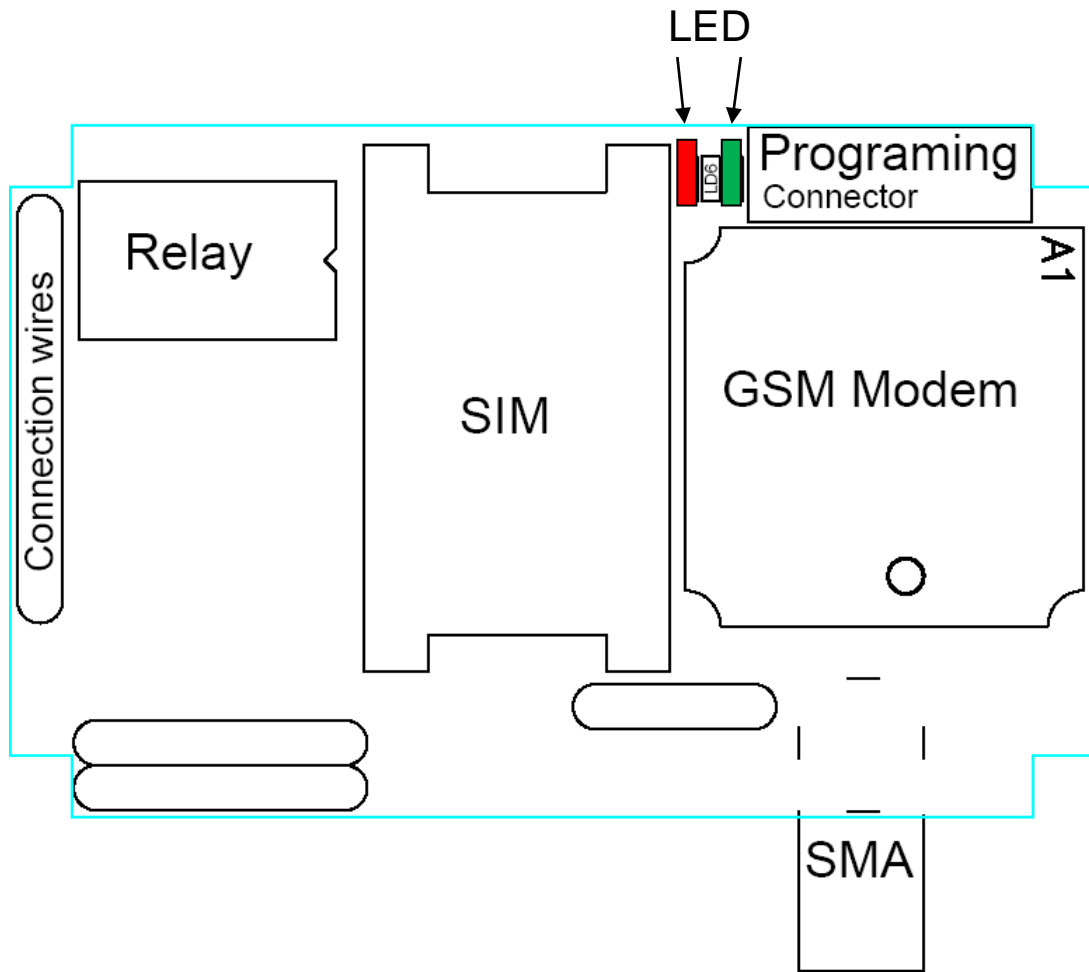

19. GSM antenna

The GSM antenna needs to be connected to the SMA connector in the front panel. Use an external antenna with SMA connection, Maximum 2.5dB.

20 Power Supply

The power supply for the SMS Alert Gate Opener has to be a single voltage source of POWER 6V-30V capable of providing a peak during an active transmission. The SMS Alert Gate Opener is protected from supply voltage reversal. An internal fuse ensures an electrical safety according to EN60950. This fuse is not removable.

20.1 Supply voltage requirements

A DC power supply must be connected to the Power input:

- Input voltage range 6V - 30V DC
- Nominal Voltage 12V DC
- Power Supply current rating: min. 1,2A @12V
- Power Supply ripple: max. 120mV
- Input current in idle mode: 25mA @ 12V
- Input average current while GSM network active (call, etc...): 100mA @ 12V

21. Internal Relay

An electronic gate requires dry contact activation.

The internal Relay used for controlling external circuit devices or applications.

The relay parameters: Maximum voltage = 30V @ max. 1A.

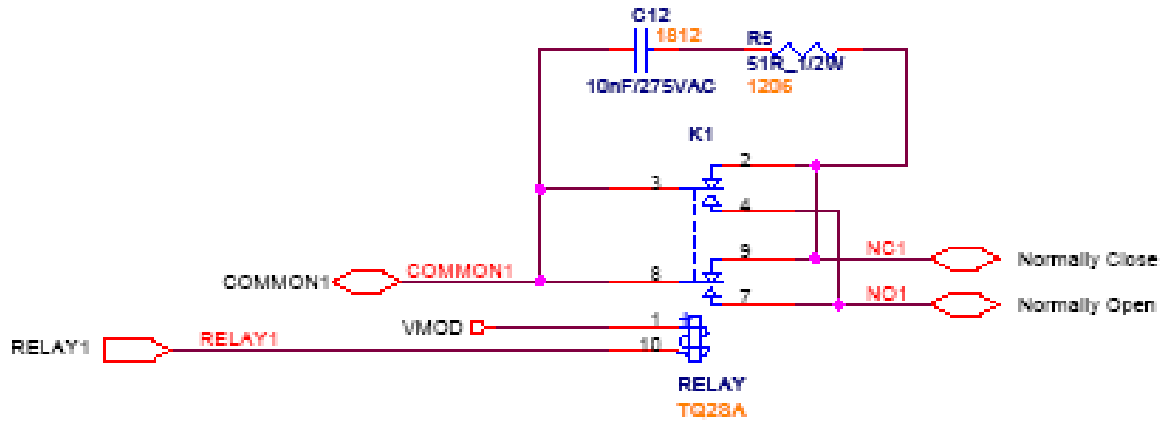

22. Unit Connection to power and relay

Option 1: SMS Alert Gate Opener direct connection to Gate Controller (gate)

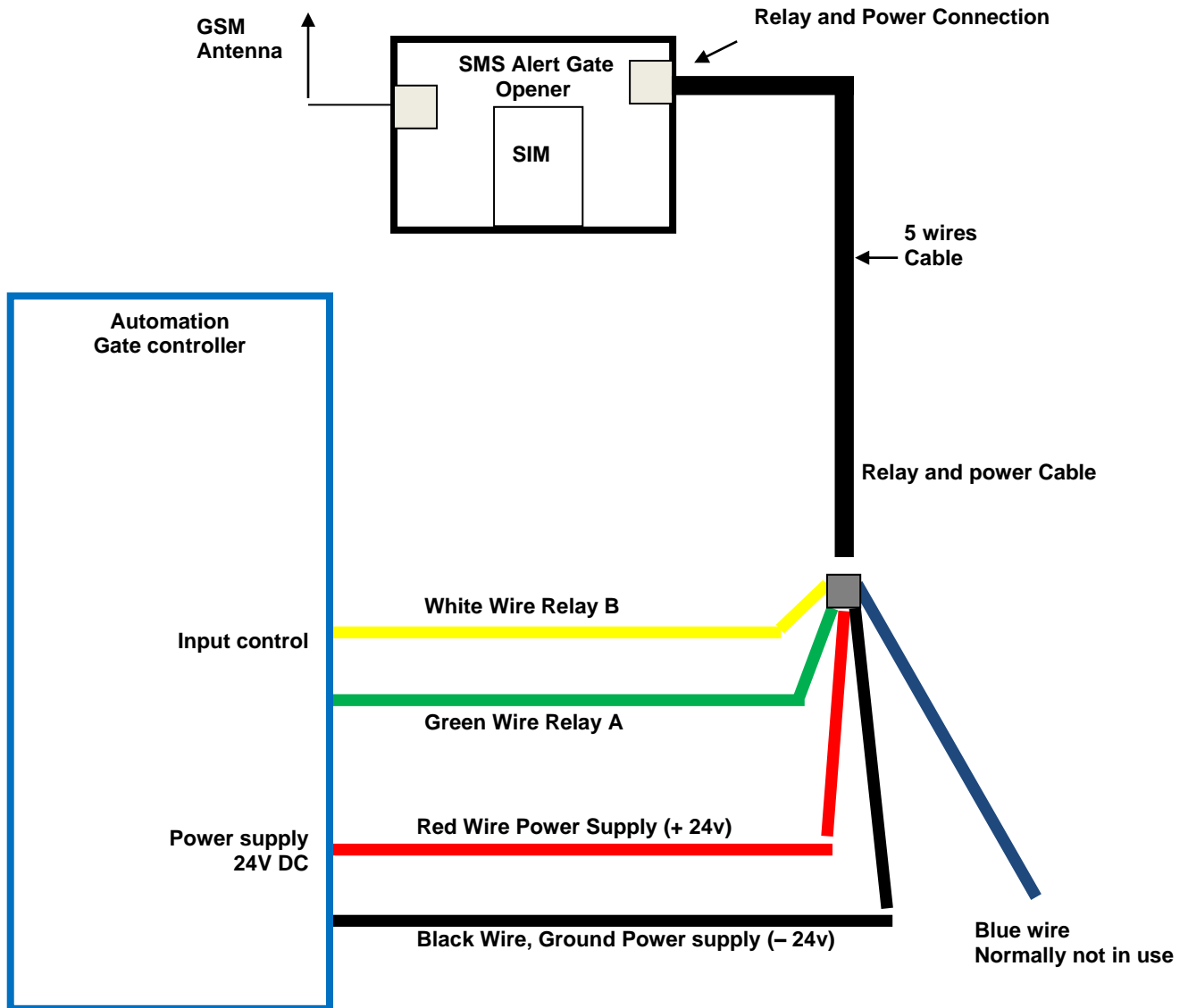

Option 2: SMS Alert Gate Opener connection to remote Controller
 This connection no needs to open the Gate controller

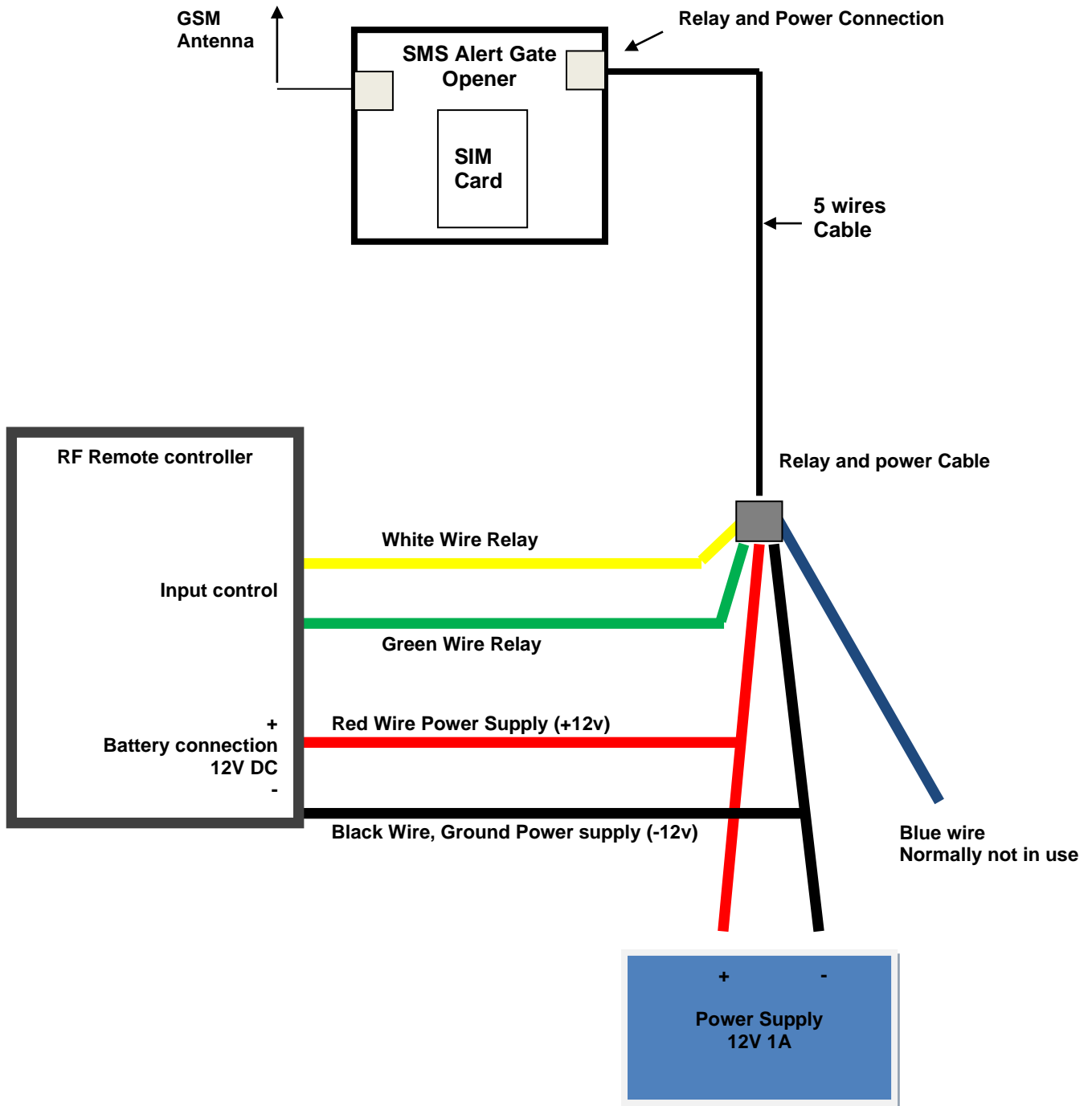

23. Unit turning on

After powering the unit on, the **RED LED** will indicate the unit connection to the GSM network. The internal software will finish being loaded within 3 minutes.

The **GREEN LED** will be turned on to indicate the unit is ready for use.

24. Access the gate\door

A registered user may call the unit and activate its output.

If the user's cellphone blocks its caller ID, he can access the unit by SMS.

If an access control by SMS is desired, the SMS: **O** needs to be sent to the unit.

(Lowercase or uppercase "**O**" means "OPEN").